

IMPORTANTE :
CACCIALANZA & C. S.p.A. si riserva il diritto di modificare senza preavviso le informazioni contenute su questa scheda con il proposito di apportare miglioramenti alla produzione

IMPORTANT :
CACCIALANZA & C. S.p.A. reserves the right to change or modify without previous notice any data or specification due to changes or modification in order to improve the products presented

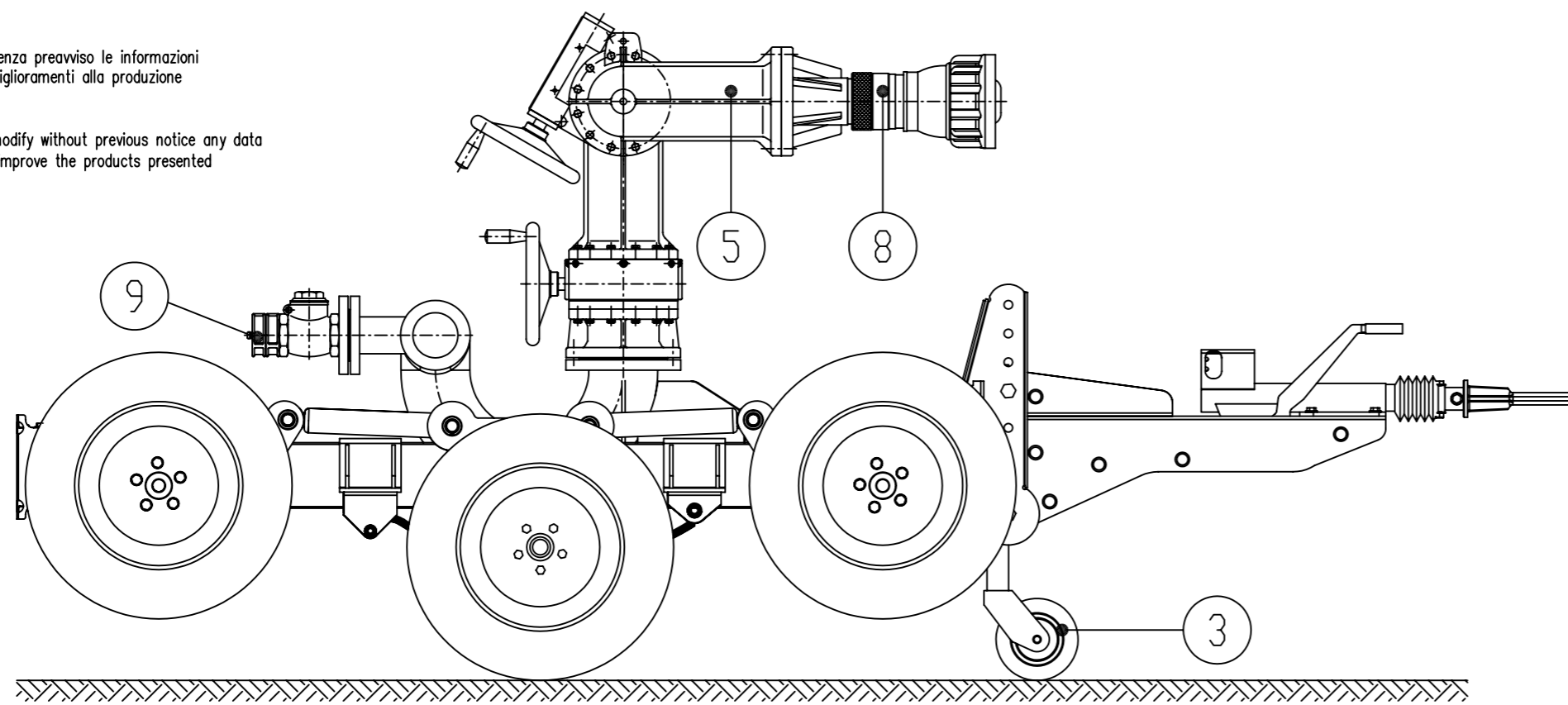

POSIZIONE DI RIPOSO

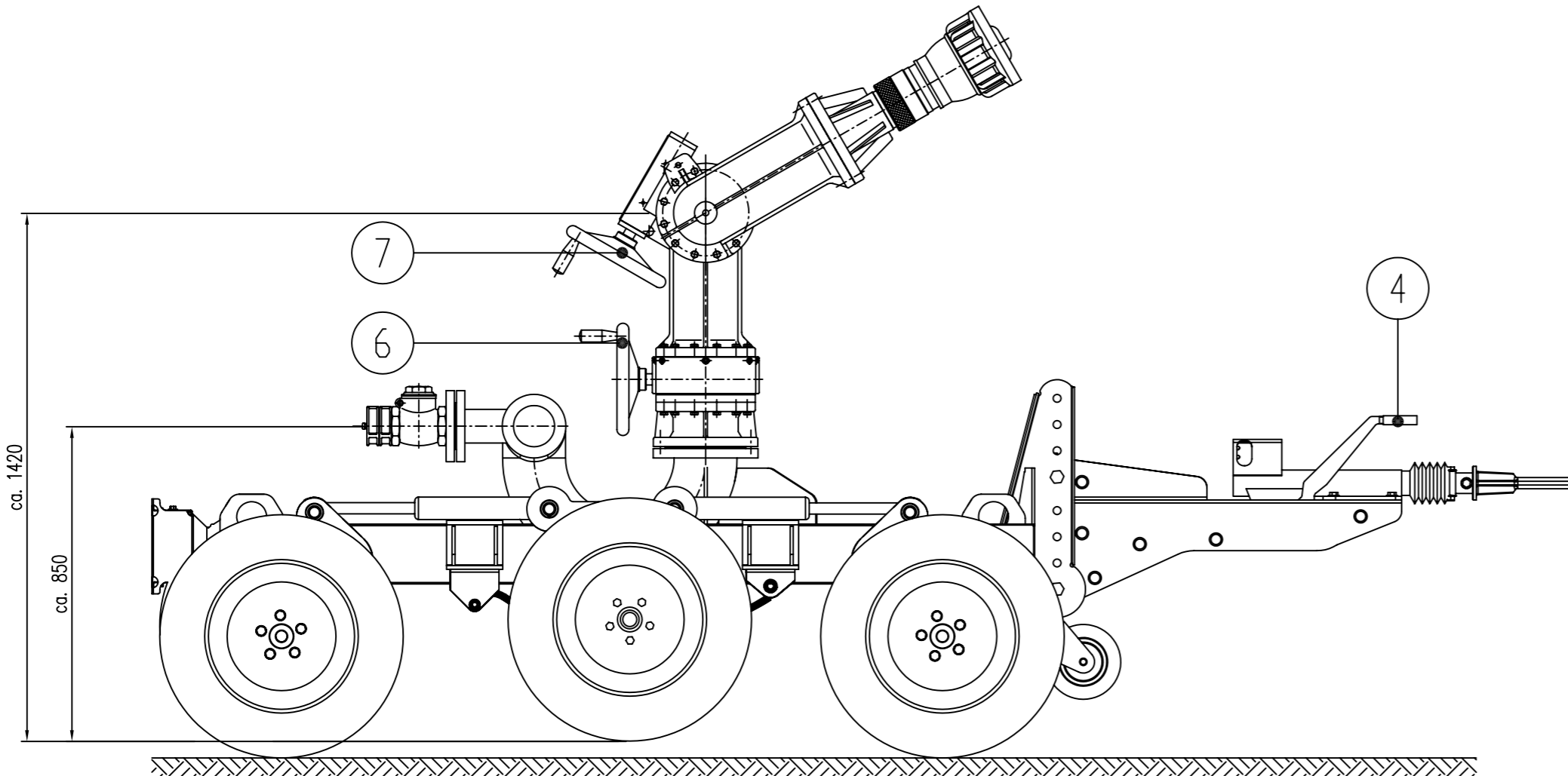
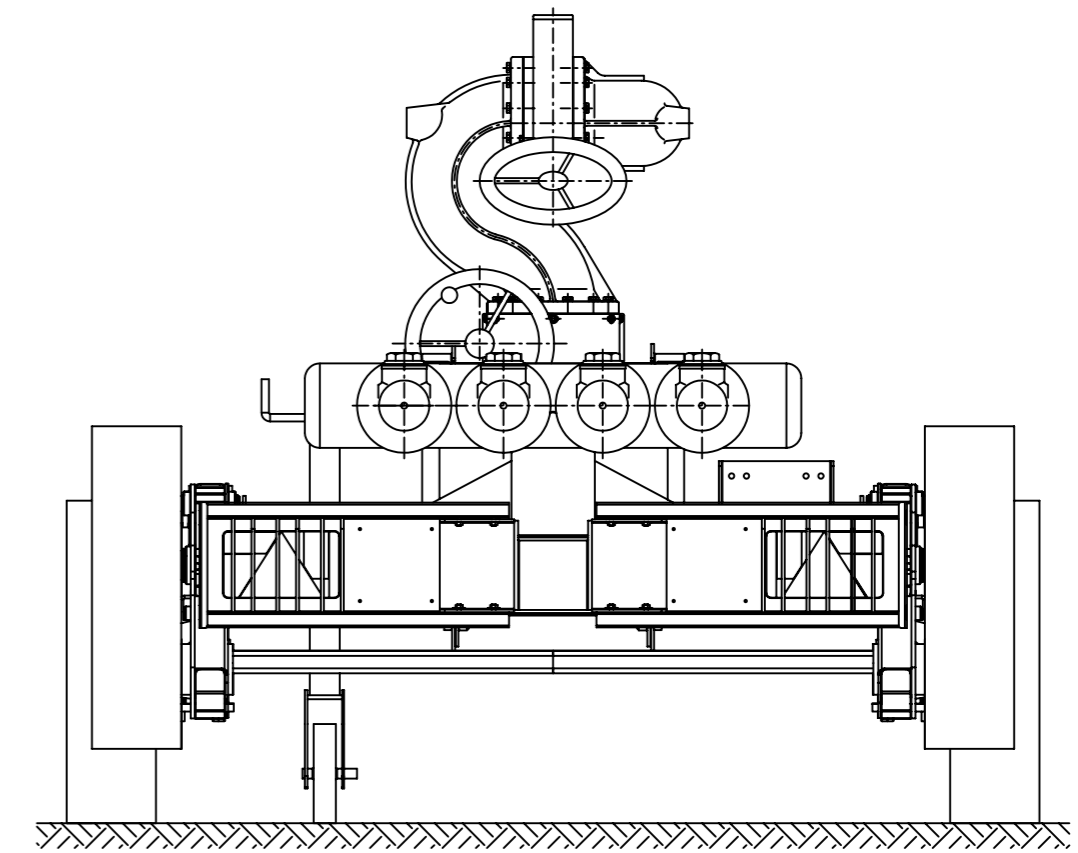

POSIZIONE DI LAVORO

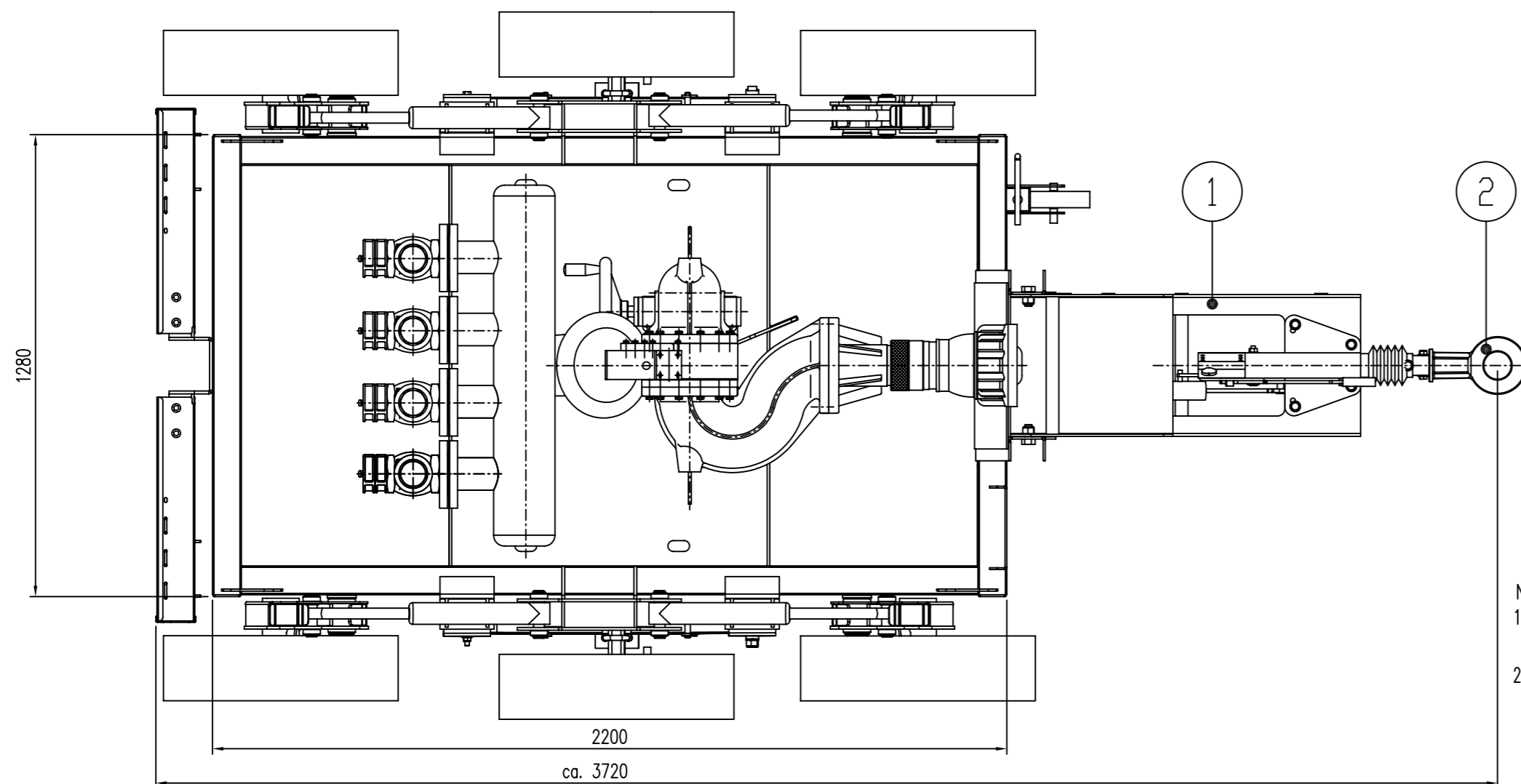
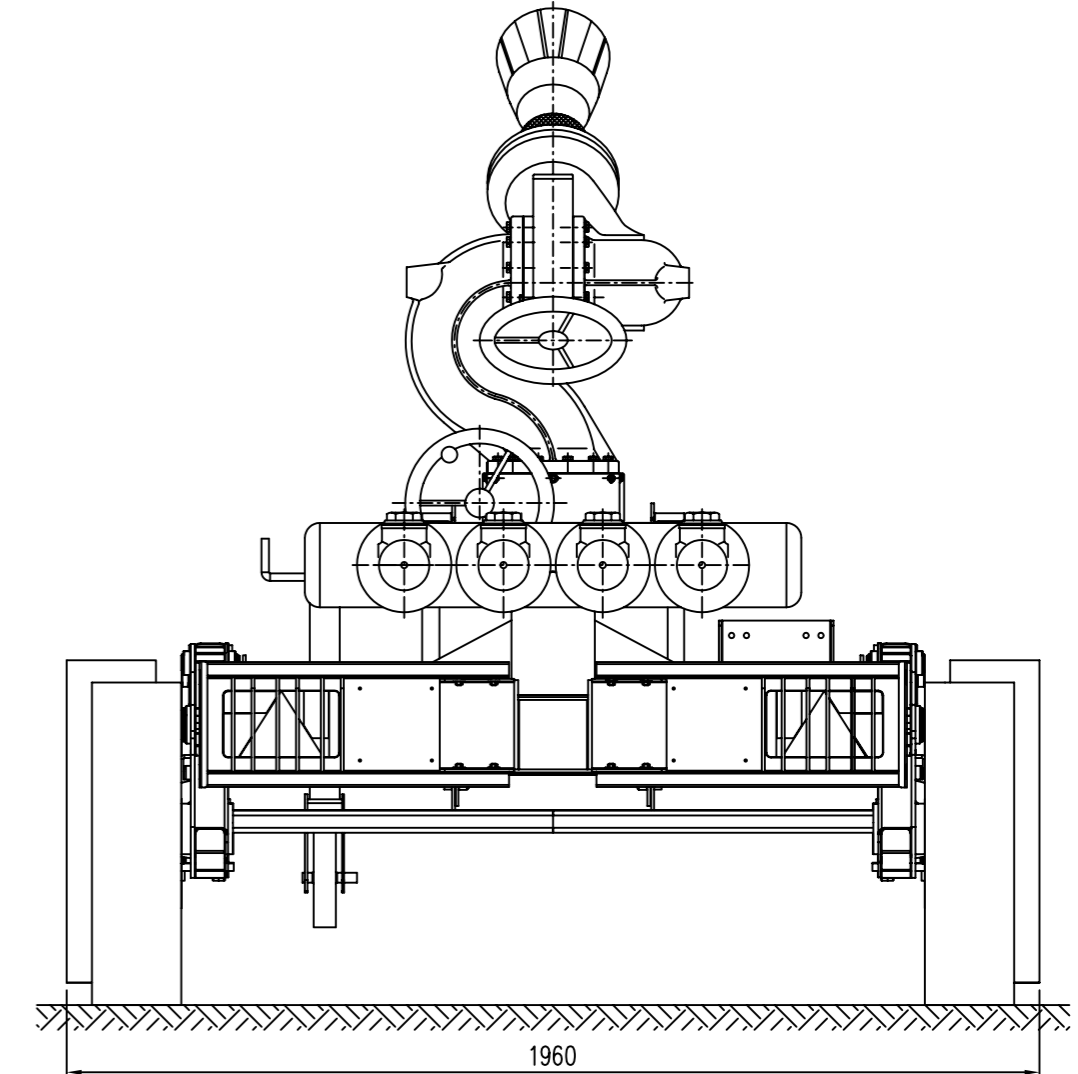

NOTE:
1-PER ESECUZIONE ASA CODICE INTERNO N. 2328271010
FOR ASA EXECUTION INTERNAL CODE N. 2328271010

2-PER ESECUZIONE DIN CODICE INTERNO N. 2328221010
FOR DIN EXECUTION INTERNAL CODE N. 2328221010

PORTATA: 1100 ÷ 7500 lt/min
FLOWRATE: 1100 ÷ 7500 lt/min

POS.	DESCRIZIONE DESCRIPTION	Q.TA Q.TY	MATERIALE MATERIAL	INT. CODE	NOTE
1	CARRELLO TRAILER	1			
2	OCCHIONE DI TRAINO TOWING EYE	1			
3	RUOTINA DI APPOGGIO BEARING WHEEL	1			
4	LEVA FRENO DI STAZIONAMENTO HAND BRAKE	1			
5	MONITORE TIPO AS6 MONITOR AS6 TYPE	1			1-2
6	VOLANTINO PER ROTAZIONE HANDWHEEL FOR ROTATION	1			
7	VOLANTINO PER ALZO HANDWHEEL FOR ELEVATION	1			
8	BOCCHELLO REGOLABILE GETTO-PIENO NEBULIZZATO TIPO MONSOON FULL-FOG ADJUSTABLE WATER NOZZLE MONSOON TYPE	1			
9	ALIMENTAZIONE IDRICA N.4 ø 3" x UNI 70 FG CON TAPPO WATER INLET N.4 ø 3" x UNI 70 FG WITH BLANK CAP	4			1-2

Rev.	Date	Description	MP Drawn	AM Checked	Approved
0	03.02.04	Emesso / Issued			
CACCIALANZA & C. S.p.A. ANTINGENIO SIOREZZA ANTINQUINAMENTO SEGRATE (MILANO) - ITALY			Client / Project		
Title			MONITORE CARRELLATO TIPO AS6 CON BOCCHELLO TIPO MONSOON ASSIEME GENERALE MONITOR TRAILER AS6 TYPE WITH MONSOON NOZZLE GENERAL ASSEMBLY		
Drawn	03.02.04	M. PELIZZARI			
Checked	03.02.04	A. MULLER			
Approved					
Code	2328271010	Sys.	Size A2	Scale 1:15	Dwg nr. 52361110
				Rev. 0	Sheet 1 of 1

THIS DRAWING IS THE PROPERTY OF CACCIALANZA & C. S.p.A. AND IS NOT TO BE REPRODUCED OR USED TO FURNISH ANY INFORMATION FOR MAKING OF DRAWINGS OR APPARATUS EXCEPT WHERE PROVIDED FOR BY AGREEMENT WITH SAID COMPANY