

IMPORTANTE :
 CACCIALANZA & C. SpA. si riserva il diritto di modificare senza preavviso le informazioni contenute su questa scheda con il proposito di apportare miglioramenti alla produzione

IMPORTANT :
 CACCIALANZA & C. SpA. reserves the right to change or modify without previous notice any data or specification due to changes or modification in order to improve the products presented

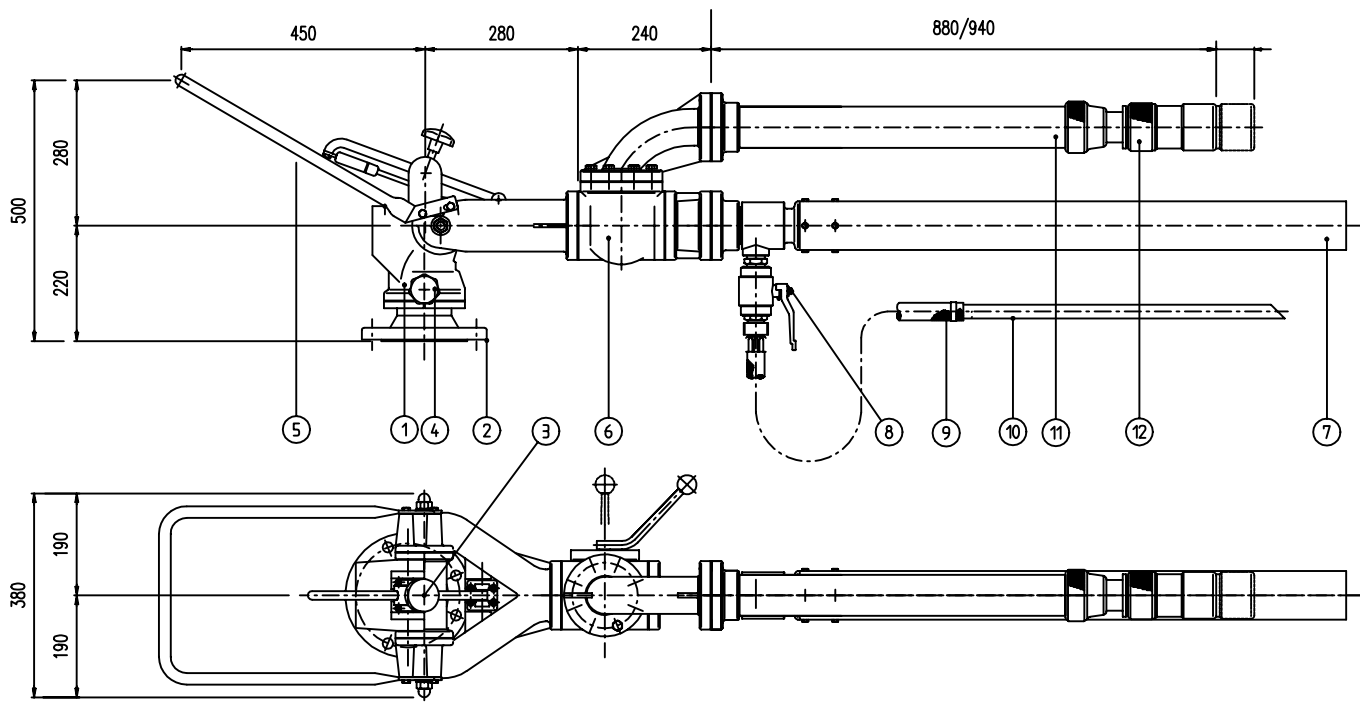

AW - 3000	1200	3000	10.0
AW - 2400	1200	2400	9.3
AW - 2000	1200	2000	8.9
AW - 1600	1200	1600	8.6
AW - 1000	1200	1000	8.2
CANNA SCHIUMA TIPO FOAM GUN TYPE	A ~	PORTATA lt/min FLOWRATE lt/min	PRESSIONE (Flg. Ingresso) Kg/cm2 PRESSURE (At. Inlet Flange) Kg/cm2

12	BOCCELLO REGOLABILE GETTO PIENO/FRAZIONATO TIPO "K" FULL/SPRAY JET ADJUSTABLE NOZZLE "K" TYPE	1		
11	CANNA IDRICA WATER GUN	1		
10	TUBO DI ASPIRAZIONE LIQUIDO SCHIUMOGENO FOAM COMPOUND SUCTION PIPE	1		
9	TUBO FLESSIBILE RINFORZATO ASP. LIQUIDO SCHIUMOGENO FOAM COMPOUND SUCTION REINFORCED FLEXIBLE HOSE	1		
8	VALVOLA A SFERA INTERCETTAZIONE ASPIRAZIONE FOAM COMPOUND SUCTION INTERCEPTION BALL VALVE	1		
7	CANNA SCHIUMA TIPO "AW" FOAM GUN "AW" TYPE	1		
6	VALVOLA COMMUTAZIONE ACQUA-SCHIUMA TIPO V1 WATER-FOAM SELECTOR VALVE V1 TYPE	1		
5	BRANDEGGIO HAND LEVER	1		
4	BLOCCAGGIO ROTAZIONE ROTATION LOCKING DEVICE	1		
3	BLOCCAGGIO ALZO ELEVATION LOCKING DEVICE	1		
2	FLANGIA D'INGRESSO INLET FLANGE	1		*
1	CORPO MONITORE TIPO A3 MONITOR BODY A3 TYPE	1		
PDS.	DESCRIZIONE DESCRIPTION	Q.TA' QTY	MATERIALE MATERIAL	NOTE NOTES

NOTE:

- * - A RICHIESTA FLG. Ø 3" ANSI 150 Lbs RF - FLGD. Ø 3" ANSI 150 Lbs RF ON REQUEST
- * - A RICHIESTA FLG. Ø 4" ANSI 150 Lbs RF - FLGD. Ø 4" ANSI 150 Lbs RF ON REQUEST
- * - A RICHIESTA FLG. UNI/DIN DN 80 PN 16 - FLGD. UNI/DIN DN 80 PN 16 ON REQUEST
- * - A RICHIESTA FLG. UNI/DIN DN 100 PN 16 - FLGD. UNI/DIN DN 100 PN 16 ON REQUEST

0	10.03.97	Emesso - Issued	MP	MB	PT
Rev.	Date	Description	Drawn	Checked	Approved
		Client / Project			
		CACCIALANZA & C. SpA. ANTINCENDIO SICUREZZA ANTINQUINAMENTO SEGRATE (MILANO) - ITALY			
		Title			
		MONITORE IDROSCHIUMA TIPO A3/B-V1-AW-K			
		ASSIEME GENERALE			
		FOAM/WATER MONITOR A3/B-V1-AW-K TYPE			
		GENERAL ASSEMBLY			
Drawn	Date	Name	Size	Scale	Dwg nr.
Checked	10.03.97	MP	A3	1:10	52059721
Approved	10.03.97	PT			
Code		Sys.			Rev.
					0
					Sheet
					1
					of
					1

THIS DRAWING IS THE PROPERTY OF CACCIALANZA & C. SpA. AND IS NOT TO BE REPRODUCED OR USED TO FURNISH ANY INFORMATION FOR MAKING OF DRAWINGS OR APPARATUS EXCEPT WHERE PROVIDED FOR BY AGREEMENT WITH SAID COMPANY