

**IMPORTANTE :**  
 CACCIALANZA & C. S.p.A. si riserva il diritto di modificare senza preavviso le informazioni contenute su questo scheda con il proposito di apportare miglioramenti alla produzione

**IMPORTANT :**  
 CACCIALANZA & C. S.p.A. reserves the right to change or modify without previous notice any data or specification due to changes or modification in order to improve the products presented

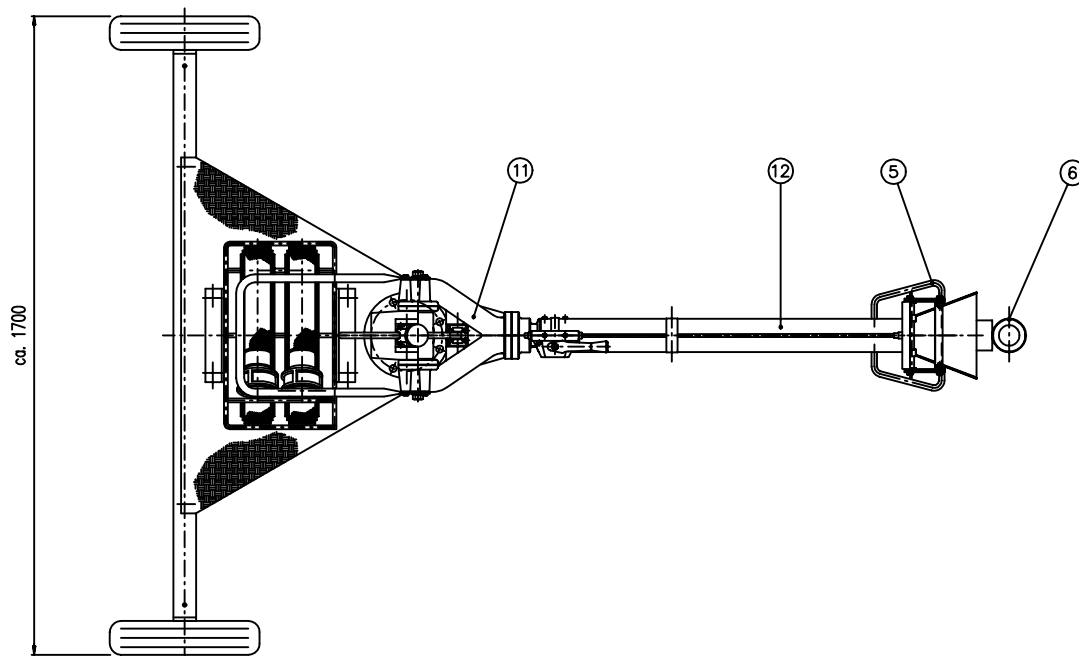
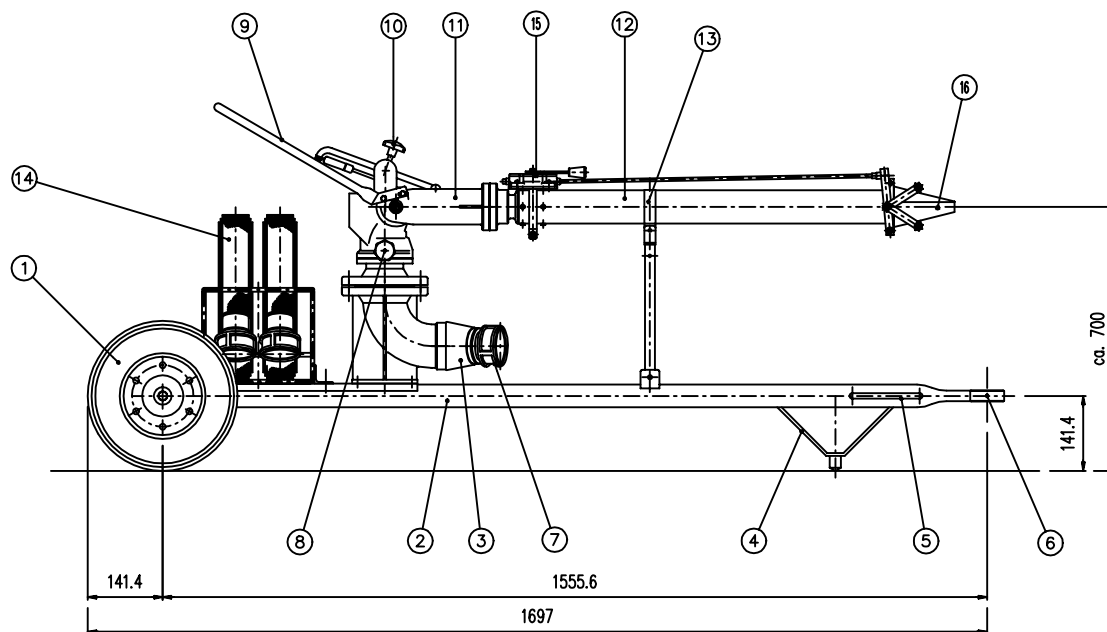

| POS. | DESCRIZIONE<br>DESCRIPTION   | Q.TA<br>Q.TY | MATERIALE<br>MATERIAL | NOTE<br>NOTES             |
|------|--|--------------|-----------------------|---------------------------|
| 1    | RUOTE #ø 400<br>WHEELS #ø 400  | 2            |                       |                           |
| 2    | CARRELLO TIPO "F1"<br>TRAILER "F1" TYPE  | 1            |                       |                           |
| 3    | ALIMENTAZIONE IDRICA 2 x ø 2 1/2"<br>WATER INLET 2 x ø 2 1/2"                              | 1            |                       |                           |
| 4    | SUPPORTO<br>SUPPORT  | 1            |                       |                           |
| 5    | MANIGLIE DI TRASPORTO<br>CARRYING HANDLE   | 2            |                       |                           |
| 6    | OCCHIONE DI TRAINO<br>TOWING EYE   | 1            |                       |                           |
| 7    | RACCORDI TIPO UNI 70<br>UNI 70 TYPE COUPLING   | 2            |                       | VEDI NOTA 1<br>SEE NOTE 1 |
| 8    | BLOCCAGGIO ROTAZIONE<br>ROTATION LOCKING DEVICE  | 1            |                       |                           |
| 9    | BRANDEGGIO MANUALE<br>HANDLE   | 1            |                       |                           |
| 10   | BLOCCAGGIO ALZO MONITORE<br>ELEVATING LOCKING DEVICE                                       | 1            |                       |                           |
| 11   | MONITORE TIPO "A3"<br>WATER/FOAM MONITOR A3 TYPE   | 1            |                       |                           |
| 12   | CANNA SCHIUMA TIPO "A"<br>FOAM GUN "A" TYPE  | 1            |                       |                           |
| 13   | SUPPORTO CANNA TIPO "A"<br>GUN SUPPORT   | 1            |                       |                           |
| 14   | MANICHETTE 2 1/2" CON RACCORDI "UNI 70"<br># 2 1/2" FLEXIBLE HOUSES WITH "UNI 70" COUPLING | 2            |                       | VEDI NOTA 1<br>SEE NOTE 1 |
| 15   | LEVA COMANDO DEFLETTORE<br>DEFLECTOR COMMAND LEVER   | 1            |                       |                           |
| 16   | DEFLETTORE<br>DEFLECTOR  | 1            |                       |                           |

**NOTE:**  
 1 - ALTRI TIPI DI RACCORDI A RICHIESTA  
 OTHER TYPE OF COUPLINGS ON REQUEST

|  |          |               |       |          |          |
|--|----------|---------------|-------|----------|----------|
| 0  | 14.06.00 | Emesso-Issued | MP    | MB       |          |
| Rev.   | Date     | Description   | Drawn | Checked  | Approved |
| <b>CACCIALANZA &amp; C.</b> s.p.a.<br>ANTINCENDIO SICUREZZA ANTINQUINAMENTO<br>SEGRATE (MILANO) - ITALY  |          |               |       |          |          |
| Client / Project<br>Title<br>MON. TIPO A3 CON CANNA SCHIUMA TIPO "A" E DEFL. MAN.<br>MONT. SU CARR. TRAINABILE TIPO "F1" - ASSEMBLE GENERALE<br>MONT. A3 TYPE WITH FOAM GUN "A" TYPE & FOAM DEFLECTOR<br>WITH COMM. LEVER MOUNTED ON "F1" TRAILER - GENERAL ASSEMBLY |          |               |       |          |          |
| Drawn  | Date     | Name          |       |          |          |
| Checked  | 14.06.00 | MP            |       |          |          |
| Approved   | 14.06.00 | MB            |       |          |          |
| Code   | Sys.     | Size          | Scale | Dwg nr.  | Rev.     |
|  |          | A2            | 1:10  | 52050050 | 0        |
| Sheet 1 of 1   |          |               |       |          |          |
| THIS DRAWING IS THE PROPERTY OF CACCIALANZA & C. S.p.A. AND IS NOT TO BE REPRODUCED OR USED TO FURNISH ANY INFORMATION FOR MAKING OF DRAWINGS OR APPARATUS EXCEPT WHERE PROVIDED FOR BY AGREEMENT WITH SAID COMPANY  |          |               |       |          |          |