

**IMPORTANTE :**

CACCIALANZA & C. S.p.A. si riserva il diritto di modificare senza preavviso le informazioni contenute su questa scheda con il proposito di apportare miglioramenti alla produzione

**IMPORTANT :**

CACCIALANZA & C. S.p.A. reserves the right to change or modify without previous notice any data or specification due to changes or modification in order to improve the products presented

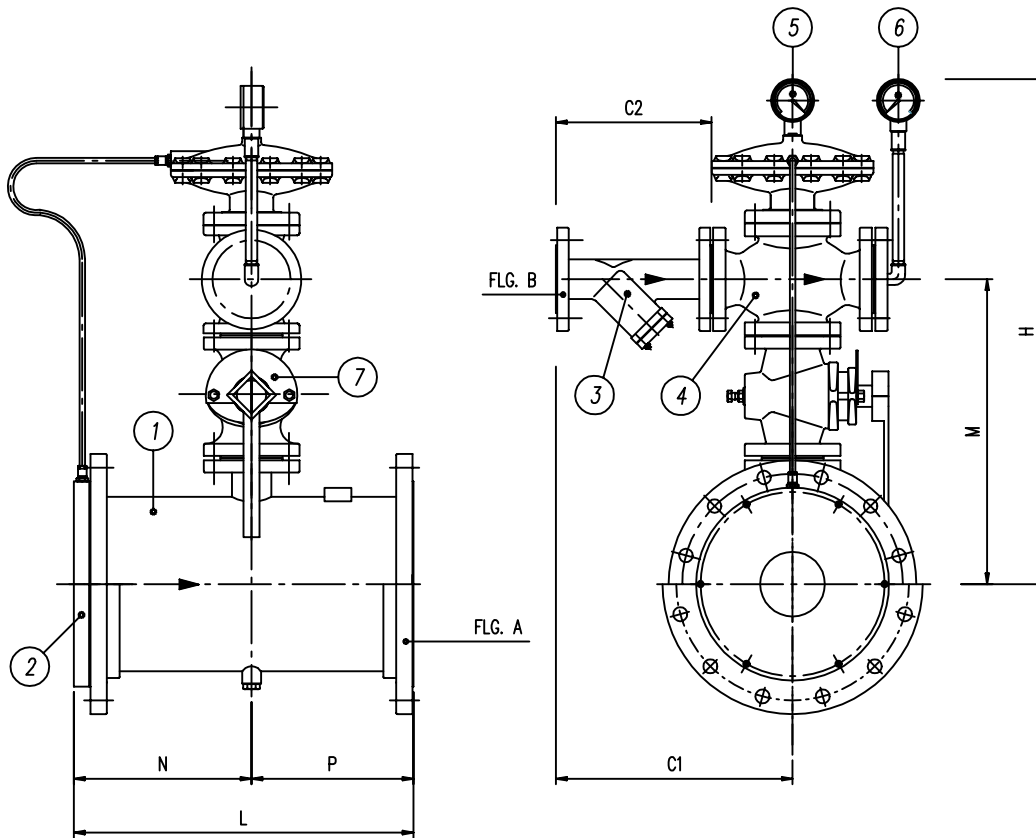

VZ-R 350	439	290	977	739	594	384	355	14"	DN 350	DN 65
VZ-R 300	439	290	932	629	566	329	300	12"	DN 300	DN 65
VZ-R 250	439	290	910	529	545	279	250	10"	DN 250	DN 65
VZ-R 200	347	230	749	432	422	230	202	8"	DN 200	DN 50
VZ-R 150	302	200	693	327	378	177	150	6"	DN 150	DN 40
VZ-R 125	302	200	680	277	365	152	125	5"	DN 125	DN 40
VZ-R 100	302	200	668	227	353	127	100	4"	DN 100	DN 40
TIPO TYPE	C 1	C 2	H	L	M	N	P	ANSI 150 FLANGIA FLANGE	UNI PN16 A	UNI PN16 FLANGIA FLANGE B

Pos.	Descrizione Description	Q.ty	Materiale Material	Code Drawing	Note
7	RUBINETTO A MASCHIO PER REGOLAZIONE % DI MISCELA PREMIXING PERCENTAGE MALE REGULATING COCK	1			
6	MANOMETRO PER LIQUIDO SCHIUMOGENO FOAM COMPOUND PRESSURE GAUGE	1			
5	MANOMETRO PER ACQUA WATER PRESSURE GAUGE	1			
4	CORPO VALVOLA VALVE BODY	1			
3	FILTRO A "Y" "Y" FILTER	1			
2	UGELLO VENTURI VENTURI NOZZLE	1			
1	CORPO VENTURI VENTURI BODY	1			

Rev.	Date	Description	Drawn	Checked	Approved		
0	17.06.1999	Emesso - Issued	MS	MB			
Date		Description	Drawn	Checked	Approved		
<b>CACCIALANZA &amp; C.</b> s.p.a. ANTINCENDIO SICUREZZA ANTINQUINAMENTO SEGRATE (MILANO) - ITALY			Client / Project				
Date			Name				
Drawn 17.06.99 MS Checked 17.06.99 MB Approved			Title MISCELATORE TIPO VZ-R 100÷350 ASSIEME GENERALE FOAM PREMIXER VZ-R 100÷350 TYPE GENERAL ASSEMBLY				
Code		Sys.	Size	Scale	Dwg nr.	Rev.	Sheet
			A 3	1:10	04200103	0	1 of 1
THIS DRAWING IS THE PROPERTY OF CACCIALANZA & C. S.p.A. AND IS NOT TO BE REPRODUCED OR USED TO FURNISH ANY INFORMATION FOR MAKING OF DRAWINGS OR APPARATUS EXCEPT WHERE PROVIDED FOR BY AGREEMENT WITH SAID COMPANY							