

**IMPORTANTE :**

CACCIALANZA & C. S.p.A. si riserva il diritto di modificare senza preavviso le informazioni contenute su questa scheda con il proposito di apportare miglioramenti alla produzione

**IMPORTANT :**

CACCIALANZA & C. S.p.A. reserves the right to change or modify without previous notice any data or specification due to changes or modification in order to improve the products presented

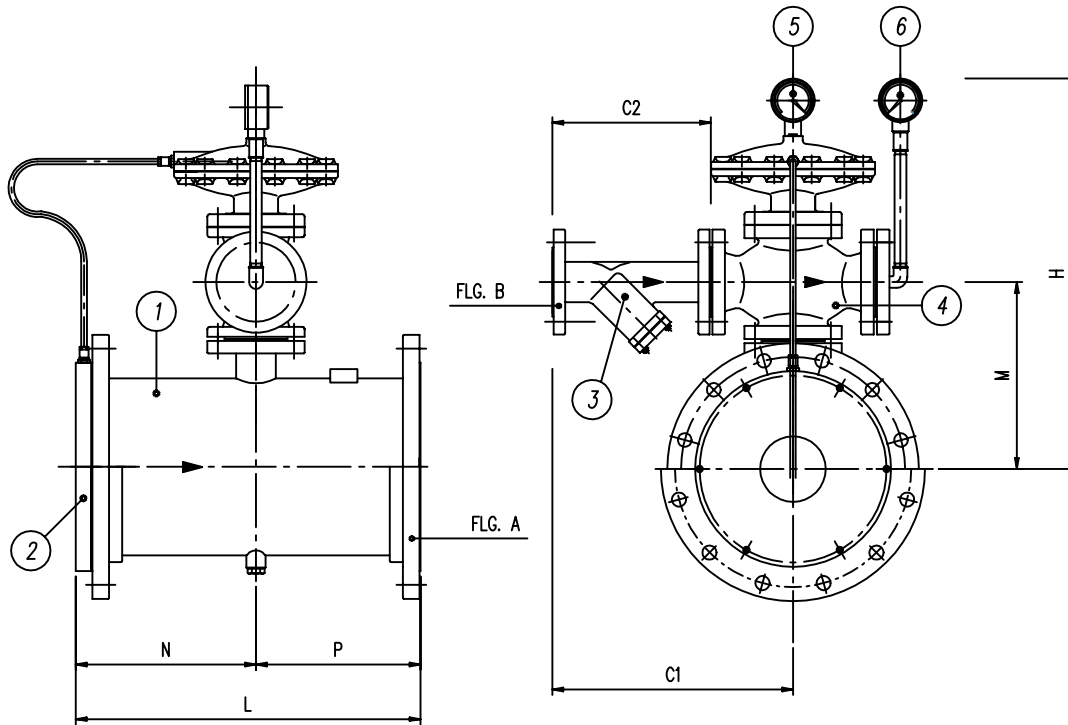

VZ 350	439	290	745	739	362	384	355	14"	DN 350	DN 65
VZ 300	439	290	700	629	334	329	300	12"	DN 300	DN 65
VZ 250	439	290	678	529	313	279	250	10"	DN 250	DN 65
VZ 200	347	230	587	432	260	230	202	8"	DN 200	DN 50
VZ 150	302	200	551	327	236	177	150	6"	DN 150	DN 40
VZ 125	302	200	538	277	223	152	125	5"	DN 125	DN 40
VZ 100	302	200	526	227	211	127	100	4"	DN 100	DN 40
TIPO TYPE	C 1	C 2	H	L	M	N	P	ANSI 150 FLANGIA FLANGE	UNI PN16 A	UNI PN16 FLANGIA FLANGE B

Pos.	Descrizione Description	Q.ty	Materiale Material	Code Drawing	Note
6	MANOMETRO PER LIQUIDO SCHIUMOGENO FOAM COMPOUND PRESSURE GAUGE	1			
5	MANOMETRO PER ACQUA WATER PRESSURE GAUGE	1			
4	CORPO VALVOLA VALVE BODY	1			
3	FILTRO A "Y" "Y" FILTER	1			
2	UGELLO VENTURI VENTURI NOZZLE	1			
1	CORPO VENTURI VENTURI BODY	1			

0	17.06.1999	Emesso - Issued	MS	MB	
Rev.	Date	Description	Drawn	Checked	Approved
		<b>CACCIALANZA &amp; C.</b> s.p.a. ANTINCENDIO SICUREZZA ANTINQUINAMENTO SEGRATE (MILANO) - ITALY	Client / Project		
			Title		
Drawn	Date		Name		
Checked	17.06.99		MB		
Approved					
Code		Sys.	Size	Scale	Dwg nr.
			A3	1:10	04200042
				Rev.	Sheet
				0	1
				of	1
THIS DRAWING IS THE PROPERTY OF CACCIALANZA & C. S.p.A. AND IS NOT TO BE REPRODUCED OR USED TO FURNISH ANY INFORMATION FOR MAKING OF DRAWINGS OR APPARATUS EXCEPT WHERE PROVIDED FOR BY AGREEMENT WITH SAID COMPANY					