

IMPORTANTE :

CACCIALANZA & C. S.p.A. si riserva il diritto di modificare senza preavviso le informazioni contenute su questa scheda con il proposito di apportare miglioramenti alla produzione

IMPORTANT :

CACCIALANZA & C. S.p.A. reserves the right to change or modify without previous notice any data or specification due to changes or modification in order to improve the products presented

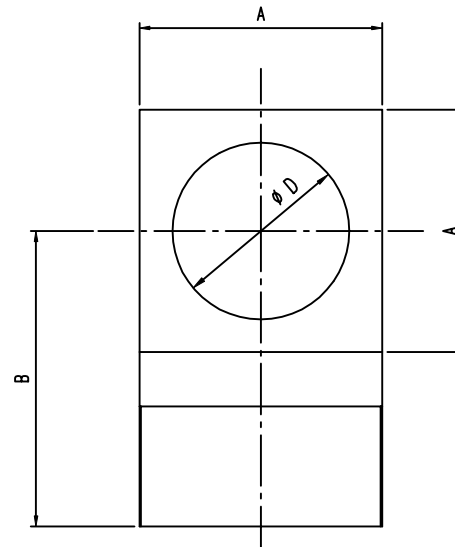
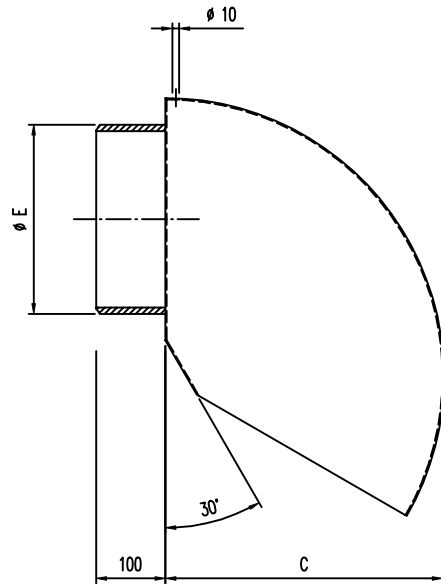

SKG 300	350	426	410	304	12"	13
SKG 250	350	426	410	254	10"	13
SKG 200	240	316	300	204	8"	9
SKG 150	240	316	300	150	6"	9
SKG 125	155	231	210	125	5"	4.5
SKG 100	155	231	210	100	4"	4.5
SKG 80	155	231	210	82	3"	4.5
TIPO TYPE	A DIMENSIONI	B -	C DIMENSIONS	ϕD	ϕE TUBO - PIPE	PESO WEIGHT Kg

0	21.06.99	Emesso - Issued	MS	MB	
Rev.	Date	Description	Drawn	Checked	Approved
CACCIALANZA & C. S.p.A. ANTINCENDIO SICUREZZA ANTINQUINAMENTO SEGRATE (MILANO) - ITALY		Client / Project			
Date		Name		Title GOMITO VERSANTE TIPO "SKG" ASSIEME GENERALE FOAM POURER "SKG" TYPE GENERAL ASSEMBLY	
Drawn	21.06.99	M. SPADA			
Checked	21.06.99	M. BARBIERI			
Approved					
Code	Sys.	Size	Scale	Dwg nr.	Rev.
		A3	1:7.5	04010110	0
					Sheet 1 of 1
THIS DRAWING IS THE PROPERTY OF CACCIALANZA & C. S.p.A. AND IS NOT TO BE REPRODUCED OR USED TO FURNISH ANY INFORMATION FOR MAKING OF DRAWINGS OR APPARATUS EXCEPT WHERE PROVIDED FOR BY AGREEMENT WITH SAID COMPANY					